

(No Model.)

N. A. DICKINSON.

BEADING ATTACHMENT FOR LATHES.

No. 343,443.

Patented June 8, 1886.

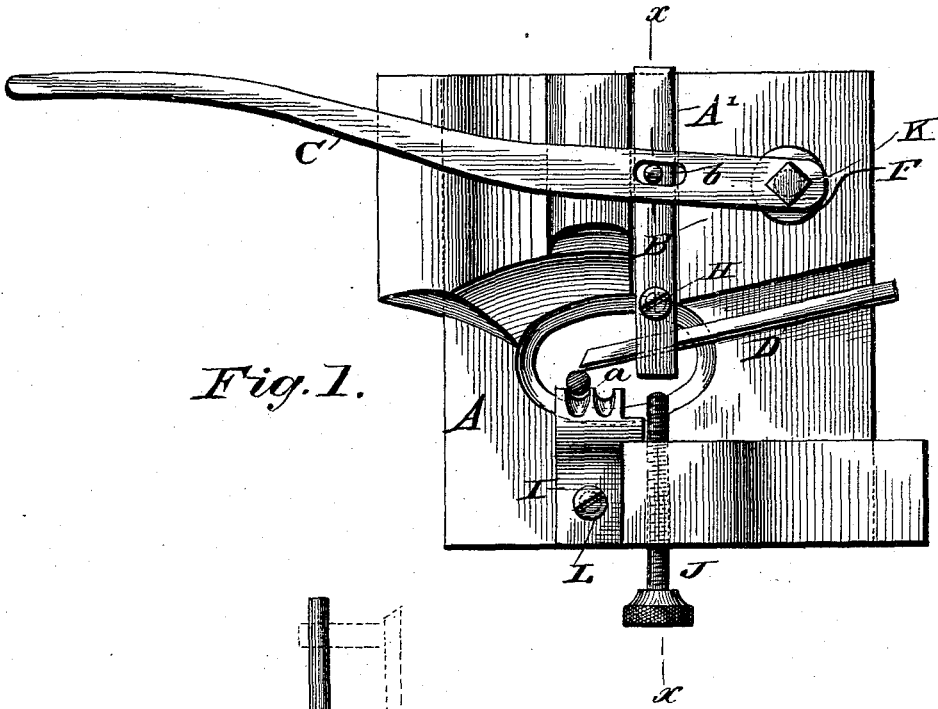

Fig. 1.

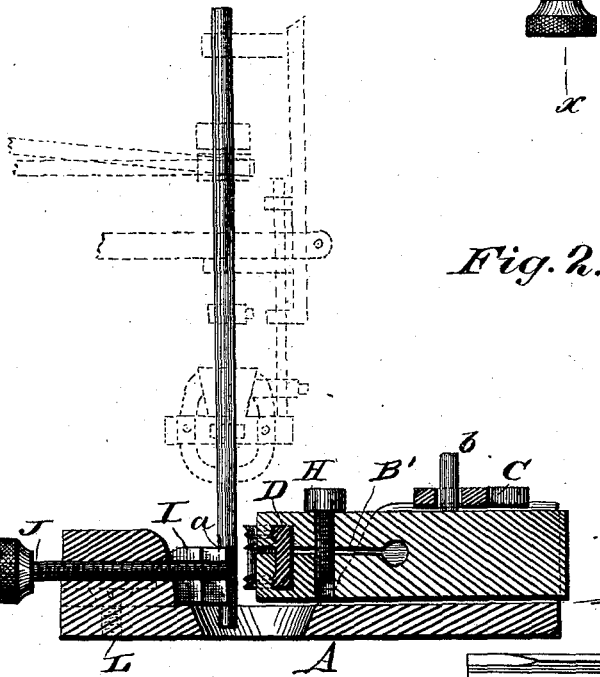

Fig. 2.

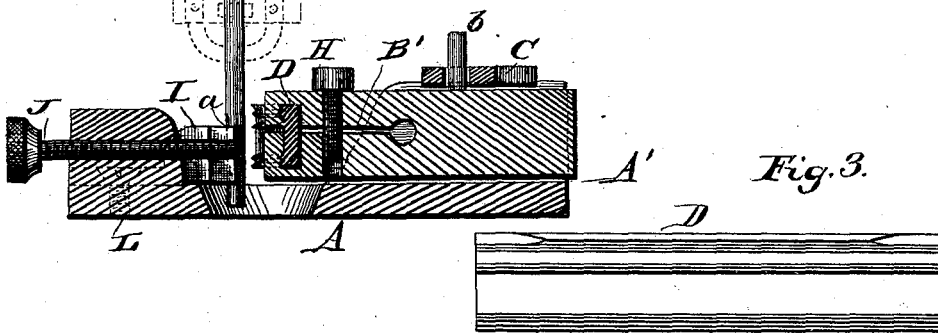

Fig. 3.

WITNESSES

*Phil Masi.*  
*Erace M. Craig*

INVENTOR

*N. A. Dickinson*  
*by Anders and Smith*  
*his* Attorneys

# UNITED STATES PATENT OFFICE.

NEWTON A. DICKINSON, OF CHESTER, CONNECTICUT.

## BEADING ATTACHMENT FOR LATHES.

SPECIFICATION forming part of Letters Patent No. 343,443, dated June 8, 1886.

Application filed February 11, 1886. Serial No. 191,036. (No model.)

*To all whom it may concern:*

Be it known that I, NEWTON A. DICKINSON, a citizen of the United States, residing at Chester, in the county of Middlesex and State of Connecticut, have invented certain new and useful Improvements in Wire and Rod Beading Attachments for Lathes and Upright Milling-Spindles; and I do declare the following to be a full, clear, and exact description of the invention, such as will enable others skilled in the art to which it appertains to make and use the same, reference being had to the accompanying drawings, and to letters or figures of reference marked thereon, which form a part of this specification.

Figure 1 of the drawings is a plan view. Fig. 2 is a vertical section on line *x x*, Fig. 1. Fig. 3 is a face view of the cutting-tool.

My invention relates to wire or rod beading attachments for lathes; and it consists in the construction and novel combination of parts, as hereinafter set forth, and pointed out in the claim.

The object of the invention is to form the beads on button-hooks, crochet-needles, and the like, the attachment being designed to be connected with a lathe or vertical or upright spindle having jaws or a chuck opening by foot-power to take in pieces of wire from which the button-hooks or crochet-needles are made.

Referring by letter to the accompanying drawings, A designates the bed-plate, which is provided with a groove, A', to hold the tool-holder B in place, the tool-holder B being mortised near one end at an angle of about fifteen degrees, to allow clearance of the tool D, and being split through for two inches or more, so that by the aid of the screw H the beading tool or knife may be held rigid. The tool D may be either a straight or curved piece of steel,

having the form of pattern wanted, planed, turned, or milled in the front face, and backed off for cutting-edge, and adjusted to center of wire or rod revolving in a groove, *a*, of the backing-die, and said tool D being clamped by screw H in the holder B. The holder B is connected, through a stud, *b*, to the pivoted lever C, pivoted on a stud, F, and attached to the base A by pin K, and the tool cuts into the wire rod running in die I until holder B meets the gage-screw J, which gages the required fullness of cut. The backing-die I is held in place by screw L. The tool D is designed to cut one or more patterns or styles of ball or bead at the same operation.

I make the tool D with patterns on its whole length, and I slide the tool and hold it by means of the lever C, so as to present a square cutting-edge to the face of the tool or pattern to be cut.

In the drawings I have shown the attachment operating in conjunction with a vertical or upright spindle having clamping-jaws for holding the steel wire to be operated upon.

Having described this invention, what I claim, and desire to secure by Letters Patent, is—

The combination, with the grooved bed-plate provided with the backing-die I and the gage-screw, of the tool-holder having the slot and set-screw, and the tool provided with patterns extending throughout its entire length, and the pivoted hand-lever for moving the tool-holder, substantially as specified.

In testimony whereof I affix my signature in presence of two witnesses.

NEWTON A. DICKINSON.

Witnesses:

E. C. HUNGERFORD,  
SAMUEL A. WRIGHT.